

REVISONS		DESCRIPTION\DATE
A1		由BJ-9101-11BGTG--R轉來\08/03/06'
A2		更換 FERRULE \10/28/09'

FOR CUSTOMER

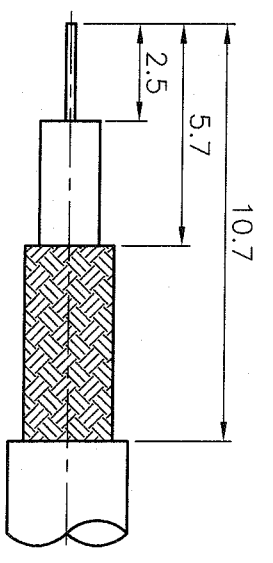

RECOMMENDED
CABLE STRIPPING DIM'S
(建議剝線尺寸)

REMARK: RoHS COMPLIANT
(符合 RoHS)

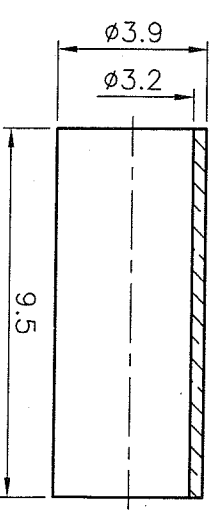
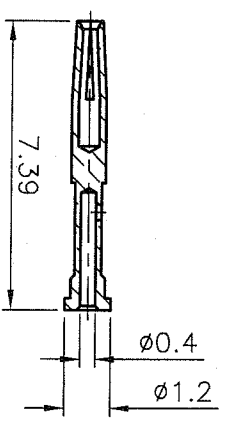
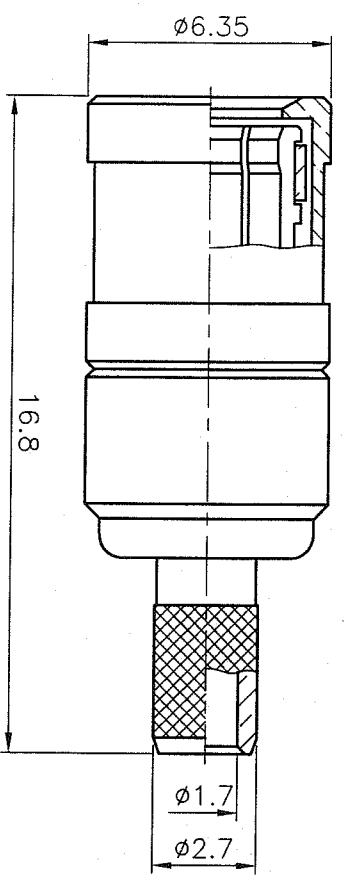

NOTES: FINISH (PLATING THICKNESS IN MICRO-INCHES)

1. BRASS PER QQ-B-626
2. GOLD PL 3 MIN OVER NICKEL PL 70 MIN THICK
3. OVER COPPER STRIKE
4. TEFLLON MIL-P-19468
5. BERYLLIUM COPPER PER QQ-C-530
6. COPPER JIS H 3300, C 1220

1. CRIMPED FERRULE
HEX CRIMP SIZE .128" (3.25mm)
(套管壓著工具)
2. CONTACT PIN TO SOLDER
(中心針焊接)



NO.	DESCRIPTION	MATERIAL	FINISH	Q'TY	DRAWING NO.	SCALE	5/1	ISSUE	A2
	FERRULE	NOTE 6	NOTE 2						
	CONTACT PIN	NOTE 5	NOTE 3						
	SHELL	NOTE 1	NOTE 2						
	C RING	NOTE 5	NONE						
	BRAID HOLDER	NOTE 1	NOTE 2						
	INSULATOR	NOTE 4	WHITE						
	BODY	NOTE 1	NOTE 2						
	DESCRIPTION	MATERIAL	FINISH	Q'TY	DRAWING NO.	SCALE	5/1	ISSUE	A2

DIMENSIONS ARE IN MILLIMETERS UNLESS OTHERWISE SPECIFIED (一般公差)		PART NO.	
0.5~6 = ±0.2	>6~30 = ±0.4	APPROVED	DATE
>30~120 = ±0.6	>120~315 = ±1.1	CHECKED	DATE
>315~1000 = ±1.6	ANGLES(角度) = ±5'	DRAWN	DATE

<p>BO-JIANG 帛江科技股份有限公司 SMB CRIMP PLUG (75 ohms) (FOR RG-179/U, 187A/U)</p>	<p>TITLE</p> <p>DRAWING NO. 9111NS711BD000B</p> <p>FILE NO. Z:\NND\9111\NS\711\000\9111NS711BD000B-A2</p>
---	--