

REVISIONS	
ISS SYMBOL	DESCRIPTION\DATE

REMARK: ROHS COMPLIANT
(符合RoHS)

FOR CUSTOMER

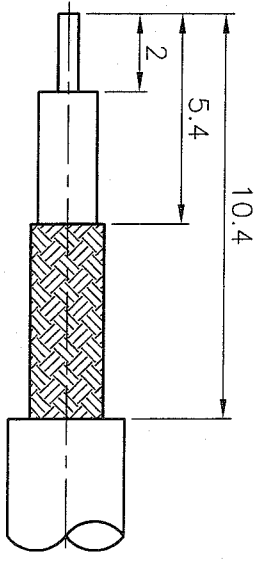

RECOMMENDED
CABLE STRIPPING DIM'S
(建議剝線尺寸)

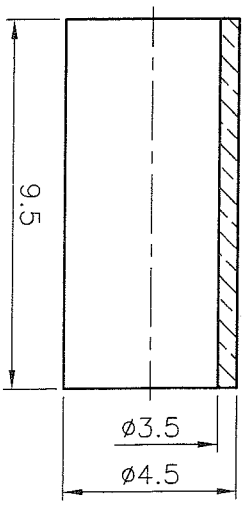
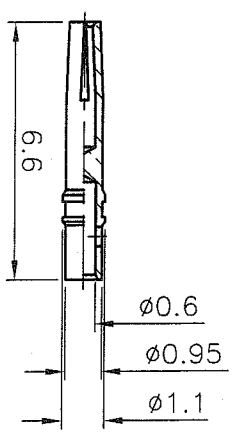
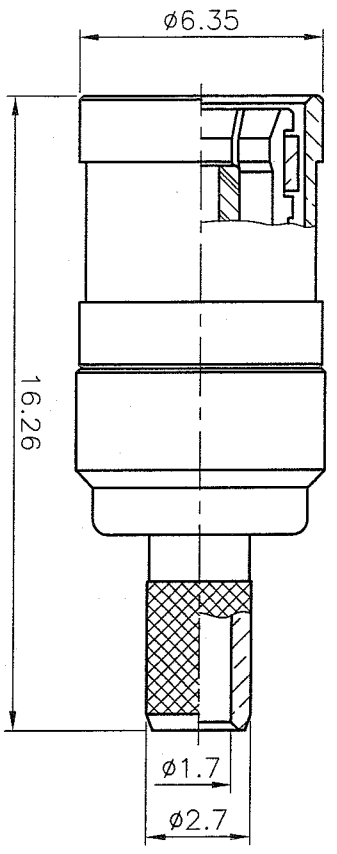

NOTES: FINISH (PLATING THICKNESS IN MICRO-INCHES)

1. BRASS PER QQ-B-626
2. GOLD PL 3 MIN THICK OVER NICKEL PL 70 MIN THICK
3. OVER COPPER STRIKE
4. TEFLON MIL-P-19468
5. BRASS JIS H 3250, C 2700
6. BERYLLIUM COPPER PER QQ-C-530

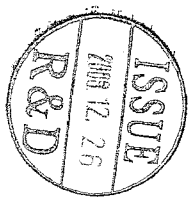

1. CRIMPED FERRULE
HEX CRIMP SIZE .151" (3.84mm)
(套管壓著工具)
2. CONTACT PIN TO SOLDER
(中心針焊接)

NO.	DESCRIPTION	MATERIAL	FINISH	Q'TY	DRAWING NO.
	FERRULE	NOTE 5	NOTE 2		
	CONTACT PIN	NOTE 6	NOTE 3		
	SHELL	NOTE 1	NOTE 2		
	C RING	NOTE 6	NONE		
	BRAID HOLDER	NOTE 1	NOTE 2		
	INSULATOR	NOTE 4	WHITE		
	INSULATOR	NOTE 4	WHITE		
	BODY	NOTE 1	NOTE 2		

DIMENSIONS ARE IN MILLIMETERS UNLESS OTHERWISE SPECIFIED			
TOLERANCES (一般公差)			
0.5~6	= ±0.2		
>6~30	= ±0.4		
>30~120	= ±0.6		
>120~315	= ±1		
>315~1000	= ±1.6		
ANGLES(角度) = ±5°			
SCALE	5/1		
ISSUE	A1		

PART NO.		APPROVED	
DATE		DATE	
CHECKED		DATE	
DRAWN		DATE	

BO-JIANG 帛江科技股份有限公司
BO-JIANG TECHNOLOGY CO., LTD.

TITLE
SMB CRIMP PLUG
(FOR 316/U DOUBLE BRAID)

DRAWING NO. 9111NSS510BD000B

FILE NO. Z:\NND\9111\NS\510\000\9111NSS510BD000B-A1