

ISS SYMBOL	DESCRIPTION\DATE
A2	更換 FERRULE \ 10/28/09'

REVISIONS

REMARK: ROHS COMPLIANT
(符合 RoHS)

FOR CUSTOMER

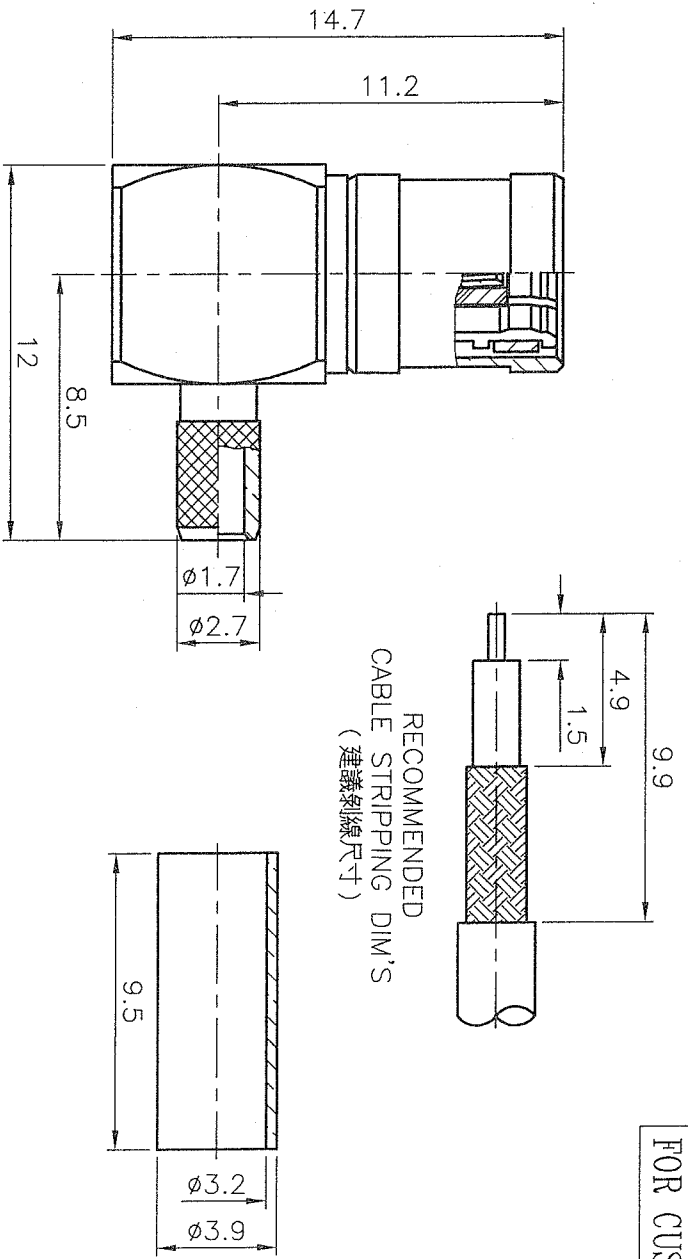

- NOTES: FINISH (PLATING THICKNESS IN MICRO-INCHES)
1. BRASS PER QQ-B-626
 2. GOLD PL 3 MIN OVER NICKEL PL 70 MIN THICK OVER COPPER STRIKE
 3. GOLD PL 30 MIN OVER NICKEL PL 70 MIN THICK OVER COPPER STRIKE
 4. TEFLON MIL-P-19468
 5. BERYLLIUM COPPER PER QQ-C-530
 6. COPPER JIS H 3300, C 1220

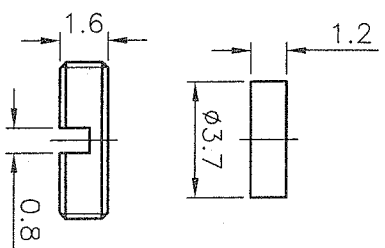

1. CRIMPED FERRULE
HEX CRIMP SIZE .128" (3.25mm)
(套管壓管工具)
2. CONTACT PIN TO SOLDER
(中心針銲接)

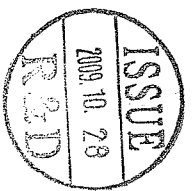

NO.	DESCRIPTION	MATERIAL	FINISH	QTY	DRAWING NO.
	NUT	NOTE 1	NOTE 2		
	SPACER	NOTE 4	WHITE		
	FERRULE	NOTE 6	NOTE 2		
	SHELL	NOTE 1	NOTE 2		
	C RING	NOTE 5	NONE		
	CUBE BODY	NOTE 1	NOTE 2		
	CONTACT PIN	NOTE 5	NOTE 3		
	INSULATOR	NOTE 4	WHITE		
	BODY	NOTE 1	NOTE 2		

DIMENSIONS ARE IN MILLIMETERS
UNLESS OTHERWISE SPECIFIED
TOLERANCES
(一般公差)
0.5~6 = ±0.2
>6~30 = ±0.4
>30~120 = ±0.6
>120~315 = ±1
>315~1000 = ±1.6
ANGLES(角度) = ±5°

PART NO.	APPROVED	DATE
	CHECKED	DATE
DRAWN		DATE
SCALE	4/1	ISSUE
A2		A2

BO-JIANG 帛江科技股份有限公司
BO-JIANG TECHNOLOGY CO., LTD.
SMB R/A CRIMP PLUG
(FOR RG-174/U,188A/U,316/U)

DRAWING NO. 9111NR509BD000B

FILE NO. Z:\NND\9111\NR\509\000\9111NR509BD000B-A2