

FOR CUSTOMER

ISSYMBOL	DESCRIPTION\DATE	REVISIONS
A2	取消局部退火\06/19/08'	

REMARK: ROHS COMPLIANT  
(符合 RoHS)

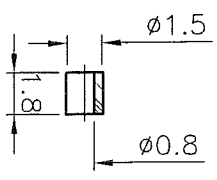
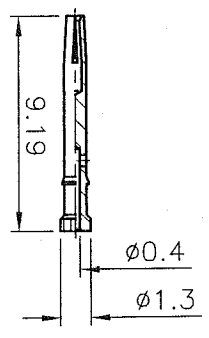
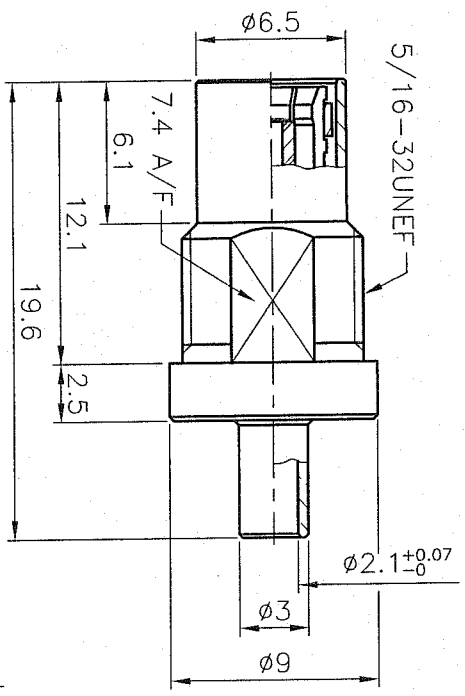
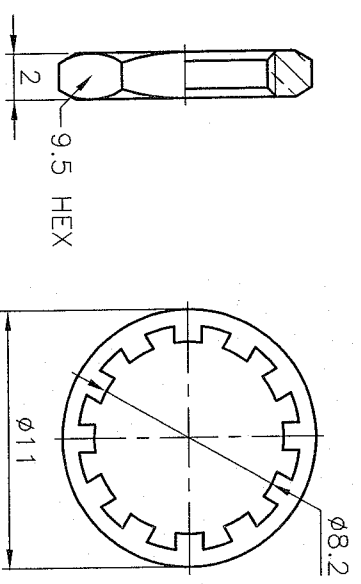
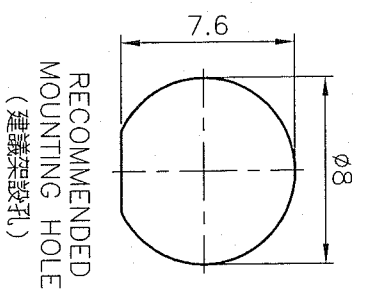
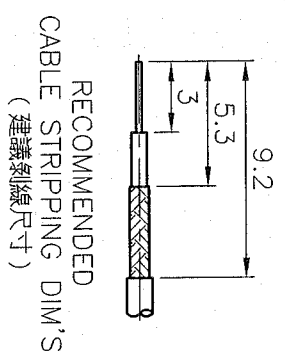
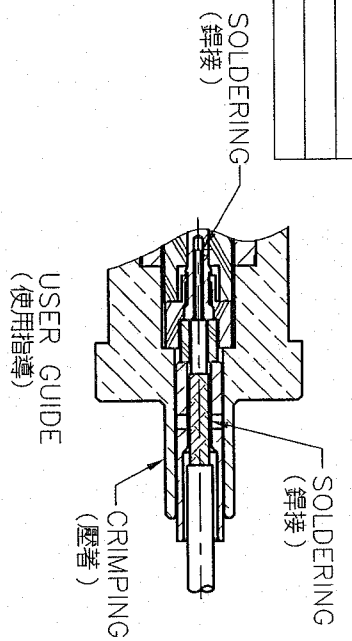

- NOTES: FINISH (PLATING THICKNESS IN MICRO-INCHES)
1. BRASS PER QQ-B-626
  2. GOLD PL 3 MIN OVER NICKEL PL 70 MIN THICK OVER COPPER STRIKE
  3. GOLD PL 30 MIN OVER NICKEL PL 70 MIN THICK OVER COPPER STRIKE
  4. TEFLON MIL-P-19468
  5. BERYLLIUM COPPER PER QQ-C-530
  6. BRASS PER QQ-B-613

NO.	DESCRIPTION	MATERIAL	FINISH	Q'TY	DRAWING NO.
	NUT	NOTE 1	NOTE 2		
	WASHER	NOTE 6	NOTE 2		
	SPACER	NOTE 1	NOTE 2		
	SPACER	NOTE 4	WHITE		
	CONTACT PIN	NOTE 5	NOTE 3		
	BODY	NOTE 1	NOTE 2		
	C RING	NOTE 5	NONE		
	INSULATOR	NOTE 4	WHITE		
	INSULATOR	NOTE 4	WHITE		
	CONTACT BODY	NOTE 1	NOTE 2		

DIMENSIONS ARE IN MILLIMETERS  
UNLESS OTHERWISE SPECIFIED  
TOLERANCES  
(一般公差)

- 0.5~6 = ±0.2
- >6~30 = ±0.4
- >30~120 = ±0.6
- >120~315 = ±1
- >315~1000 = ±1.6
- ANGLES(角度) = ±5'

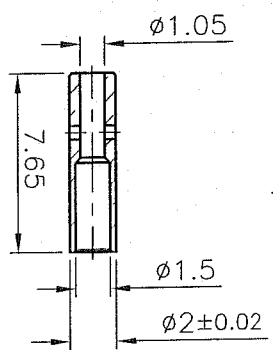

1. CRIMPED FERRULE  
HEX CRIMP SIZE .100" (2.54mm)  
(套管压着工具)
2. CONTACT PIN TO SOLDER  
(中心针焊接)
3. MAX. PANEL THICKNESS=3mm  
(最大板厚)

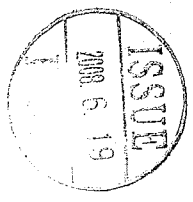

PART NO.	
APPROVED	DATE 06/19/08'
CHECKED	DATE 06/19/08'
DRAWN	DATE 06/19/08'

**BO-JIANG** 帛江科技股份有限公司  
BO-JIANG TECHNOLOGY CO., LTD.

TITLE: SMB BULKHEAD CRIMP PLUG  
(FOR 1.13mm, 1.32mm)

DRAWING NO. 9111BS534BD000B

FILE NO. Z:\NND\9111\BS\534\000\9111BS534BD000B-A2