

REVISIONS		
ISS	SYMBOL	DESCRIPTION\DATE

FOR CUSTOMER

REMARK: RoHS COMPLIANT
(符合 RoHS)

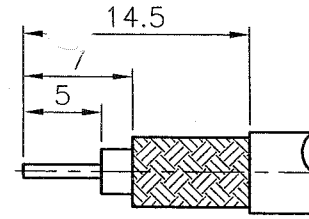

RECOMMENDED
CABLE STRIPPING DIM'S
(建議剝線尺寸)

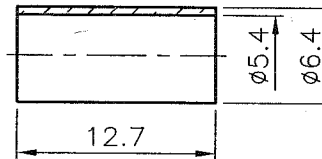
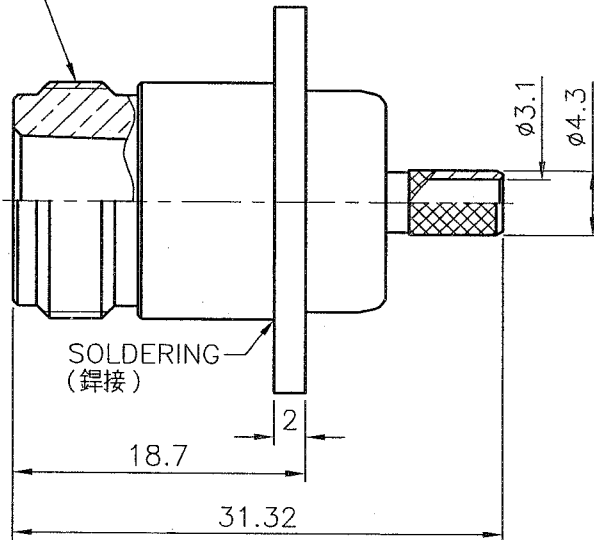
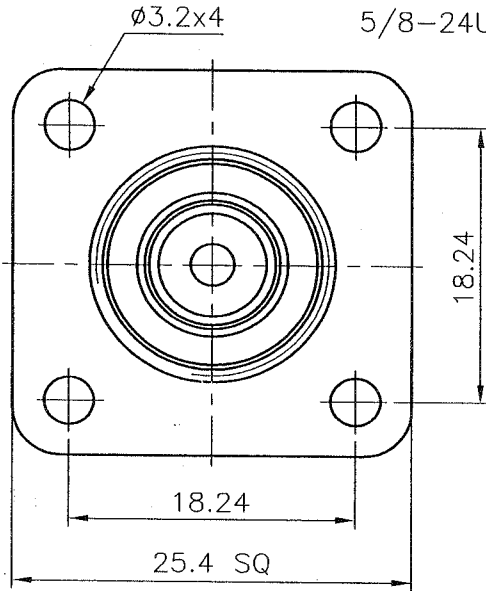
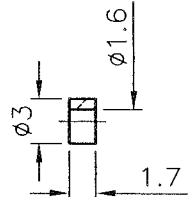
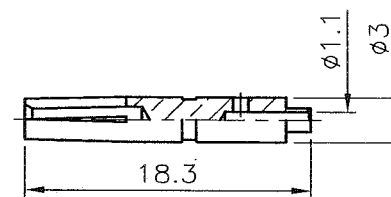

NOTES: FINISH (PLATING THICKNESS IN MICRO-INCHES)

- BRASS PER QQ-B-626
- NICKEL PL 70 MIN THICK OVER COPPER STRIKE
- GOLD PL 3 MIN OVER NICKEL PL 70 MIN THICK OVER COPPER STRIKE
- TEFLON MIL-P-19468
- PHOSPHOR BRONZE PER QQ-B-750
- BRASS JIS H 3250, C 2700

- CRIMPED FERRULE
HEX CRIMP SIZE .213" (5.41mm)
(套管壓著工具)
- CRIMPED CONTACT PIN
HEX CRIMP SIZE .100" (2.54mm)
(中心針壓著工具)



					DIMENSIONS ARE IN MILLIMETERS				PART NO.	
FERRULE	NOTE 6	NOTE 2			UNLESS OTHERWISE SPECIFIED TOLERANCES (一般公差) 0.5~6 = ±0.2 >6~30 = ±0.4 >30~120 = ±0.6 >120~315 = ±1 >315~1000 = ±1.6 ANGLES(角度) = ±5°				APPROVED	DATE
SPACER	NOTE 4	WHITE							<i>[Signature]</i>	08/30/06'
CONTACT PIN	NOTE 5	NOTE 3							CHECKED	DATE
BRAID HOLDER	NOTE 1	NOTE 2							<i>[Signature]</i>	08/30/06'
INSULATOR	NOTE 4	WHITE							DRAWN	DATE
MAIN BODY	NOTE 1	NOTE 2							<i>[Signature]</i>	08/30/06'
NO.	DESCRIPTION	MATERIAL	FINISH	Q'TY	DRAWING NO.	SCALE	2/1	ISSUE	A1	

BO-JIANG 帛江科技股份有限公司
BO-JIANG TECHNOLOGY CO., LTD.

TITLE: N PANEL CRIMP JACK
(FOR RG-58C/U,58/U)

DRAWING NO. **7361FS501BF000B**

FILE NO. Z:\NND\7361\F5\501\000\BFB-A1