

ISS		SYMBOL		DESCRIPTION\DATE	
A1		由BJ-7310-09BNTG-R 型號轉來\08/29/06'			

FOR CUSTOMER

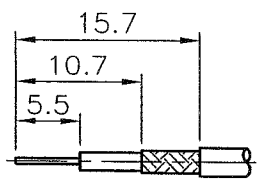

RECOMMENDED
CABLE STRIPPING DIM'S
(建議剝線尺寸)

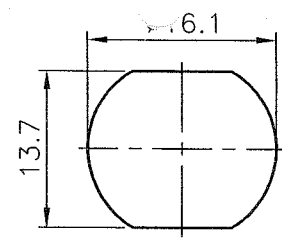

RECOMMENDED
MOUNTING HOLE
(建議架設孔)

REMARK: RoHS COMPLIANT
(符合 RoHS)

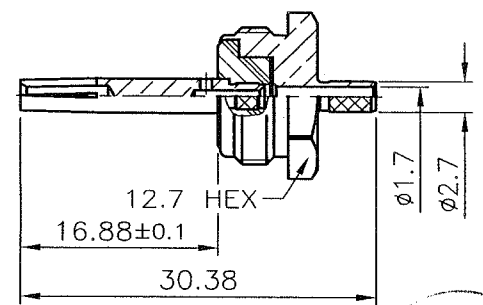
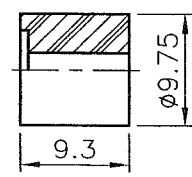
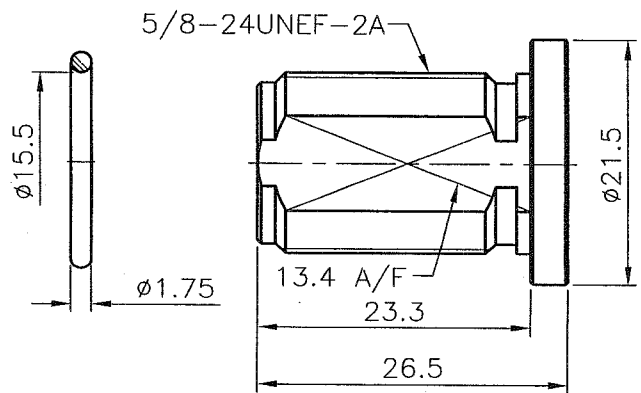
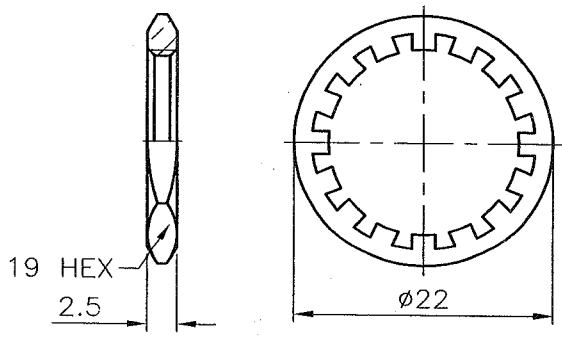

- NOTES: FINISH (PLATING THICKNESS IN MICRO-INCHES)
1. BRASS PER QQ-B-626
 2. NICKEL PL 70 MIN THICK OVER COPPER STRIKE
 3. GOLD PL 3 MIN OVER NICKEL PL 70 MIN THICK OVER COPPER STRIKE
 4. TEFLON MIL-P-19468
 5. PHOSPHOR BRONZE PER QQ-B-750
 6. BRASS JIS H 3100, C 2680
 7. BRASS JIS H 3250, C 2700

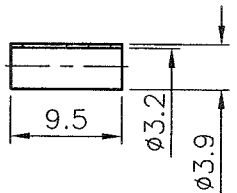

1. CRIMPED FERRULE
HEX CRIMP SIZE .128" (3.25mm)
(套管壓著工具)
2. CONTACT PIN TO SOLDER
(中心針銲接)
3. MAX. PANEL THICKNESS=8.5mm
(最大板厚)

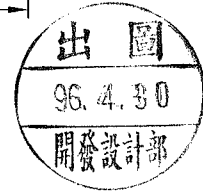

NO.	DESCRIPTION	MATERIAL	FINISH	Q'TY	DRAWING NO.
	NUT				
	WASHER				
	GASKET	RUBBER	BLACK		
	FERRULE				
	BRAID HOLDER				
	INSULATOR		WHITE		
	CONTACT PIN				
	INSULATOR		WHITE		
	BODY				

DIMENSIONS ARE IN MILLIMETERS			
UNLESS OTHERWISE SPECIFIED TOLERANCES (一般公差)			
0.5~6	= ±0.2		
>6~30	= ±0.4		
>30~120	= ±0.6		
>120~315	= ±1		
>315~1000	= ±1.6		
ANGLES(角度) = ±5'			

PART NO.	
APPROVED	DATE
CHECKED	DATE
DRAWN	DATE

BO-JIANG BO-JIANG TECHNOLOGY CO., LTD.	
TITLE	N BULKHEAD CRIMP JACK (FOR RG-174/U,188A/U,316/U,LMR-100)
DRAWING NO.	7361DS509BF000B
FILE NO.	Z:\NND\7361\DS\509\000\BFB-A1