

ISS		SYMBOL		REVISIONS	
A2				DESCRIPTION\DATE	
				訂正 GASKET 材質 \ 11/26/08'	

REMARK: RoHS COMPLIANT
(符合 RoHS)

FOR CUSTOMER

5/8-24UNEF-2B

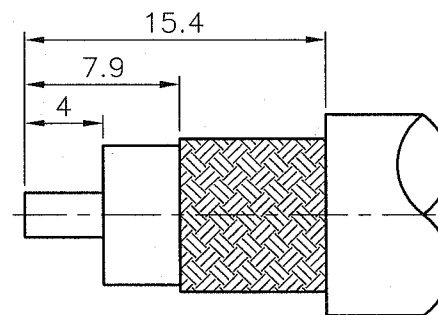
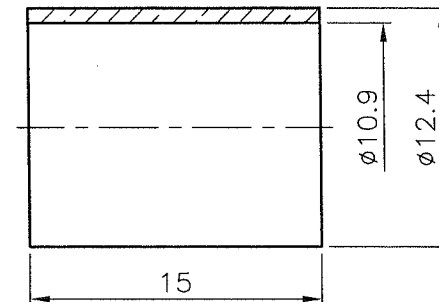
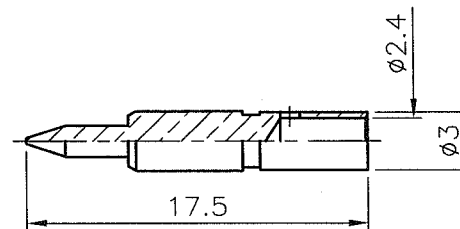
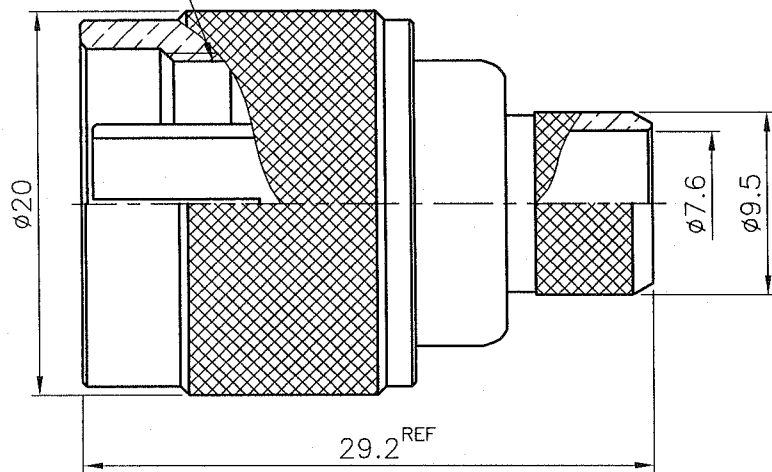

RECOMMENDED
CABLE STRIPPING DIM'S
(建議剝線尺寸)

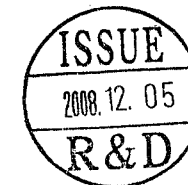

NOTES: FINISH (PLATING THICKNESS IN MICRO-INCHES)

1. BRASS PER QQ-B-626
2. NICKEL PL 70 MIN THICK OVER COPPER STRIKE
3. TEFLON MIL-P-19468
4. GOLD PL 3 MIN OVER NICKEL PL 70 MIN THICK OVER COPPER STRIKE
5. BRASS JIS H 3250, C 2700

1. CRIMPED FERRULE
HEX CRIMP SIZE .429" (10.9mm)
(套管壓著工具)
2. CRIMPED CONTACT PIN
HEX CRIMP SIZE .100" (2.54mm)
(中心針壓著工具)

NO.	DESCRIPTION	MATERIAL	FINISH	Q'TY	DRAWING NO.
	FERRULE	NOTE 5	NOTE 2		
	CONTACT PIN	NOTE 1	NOTE 4		
	SHELL	NOTE 1	NOTE 2		
	C RING	NOTE 5	NOTE 2		
	GASKET	SILICONE	ORANGE		
	BRAID HOLDER	NOTE 1	NOTE 2		
	INSULATOR	NOTE 3	WHITE		
	CONTACT BODY	NOTE 1	NOTE 2		
	BODY	NOTE 1	NOTE 2		

DIMENSIONS ARE IN MILLIMETERS			
UNLESS OTHERWISE SPECIFIED TOLERANCES (一般公差)			
0.5~6	= ±0.2		
>6~30	= ±0.4		
>30~120	= ±0.6		
>120~315	= ±1		
>315~1000	= ±1.6		
ANGLES(角度) = ±5'			

PART NO.	
APPROVED	DATE
<i>[Signature]</i>	11/26/08'
CHECKED	DATE
<i>[Signature]</i>	11/26/08'
DRAWN	DATE
<i>[Signature]</i>	11/26/08'

 帛江科技股份有限公司 BO-JIANG TECHNOLOGY CO., LTD.	
TITLE N CRIMP PLUG (FOR RG-213/U,B8267)	
DRAWING NO. 7311NS513BF000B	
FILE NO. Z:\NND\7311\NS\513\000\7311NS513BF000B-A2	