

ISS SYMBOL		DESCRIPTION \ DATE
A1		由BJ-7301-02BNTG-R 型號轉來 \ 08/22/06'

REVISIONS

REMARK: RoHS COMPLIANT  
(符合 RoHS)

FOR CUSTOMER

5/8-24UNEF-2B

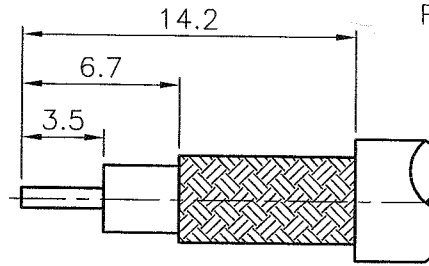
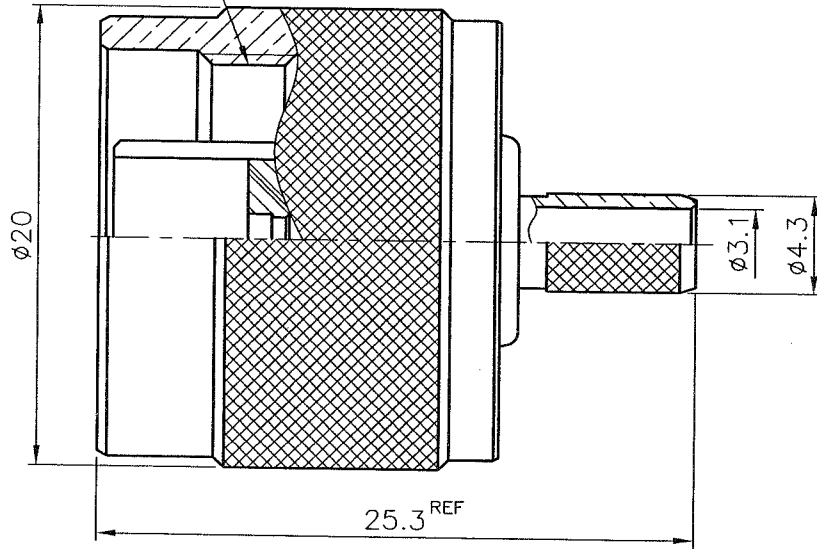

RECOMMENDED  
CABLE STRIPPING DIM'S  
(建議剝線尺寸)

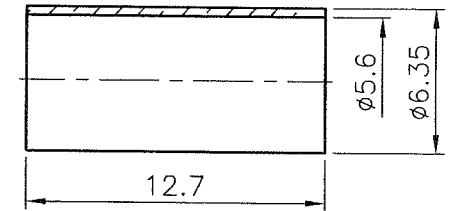
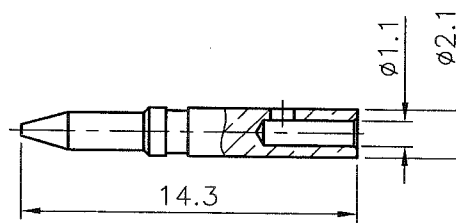

- NOTES: FINISH (PLATING THICKNESS IN MICRO-INCHES)
1. BRASS PER QQ-B-626
  2. NICKEL PL 70 MIN THICK OVER COPPER STRIKE
  3. TEFLON MIL-P-19468
  4. GOLD PL 3 MIN THICK OVER NICKEL PL 70 MIN THICK OVER COPPER STRIKE
  5. BRASS JIS H 3250,C 2700

1. CRIMPED FERRULE  
HEX CRIMP SIZE .213" (5.41mm)  
(套管壓著工具)
2. CRIMPED CONTACT PIN  
HEX CRIMP SIZE .068" (1.72mm)  
(中心針壓著工具)

NO.	DESCRIPTION	MATERIAL	FINISH	Q'TY	DRAWING NO.
	FERRULE		NOTE 5	NOTE 2	
	CONTACT PIN		NOTE 1	NOTE 4	
	SHELL		NOTE 1	NOTE 2	
	C RING		NOTE 1	NOTE 2	
	GASKET	SILICONE		RED	
	INSULATOR		NOTE 3	WHITE	
	BRAID HOLDER		NOTE 1	NOTE 2	
	BODY		NOTE 1	NOTE 2	

DIMENSIONS ARE IN MILLIMETERS  
UNLESS OTHERWISE SPECIFIED  
TOLERANCES  
(一般公差)  
0.5~6 = ±0.2  
>6~30 = ±0.4  
>30~120 = ±0.6  
>120~315 = ±1  
>315~1000 = ±1.6  
ANGLES(角度) = ±5'

PART NO.  
APPROVED [Signature] DATE 08/22/06'  
CHECKED [Signature] DATE 08/22/06'  
DRAWN [Signature] DATE 08/22/06'

**BO-JIANG** 帛江科技股份有限公司  
BO-JIANG TECHNOLOGY CO., LTD.

TITLE: N CRIMP PLUG  
(FOR RG-55/U,142A/U,223/U,400/U)

DRAWING NO. 7311NS502BF000B

FILE NO. Z:\NND\7311\NS\502\000\BFB-A1