

REVISIONS

ISS	SYMBOL	DESCRIPTION\DATE
A1		由BJ-7301-01BNTG001-R型號轉來\08/22/06'

FOR CUSTOMER

REMARK: RoHS COMPLIANT
(符合 RoHS)

5/8-24UNEF-2B

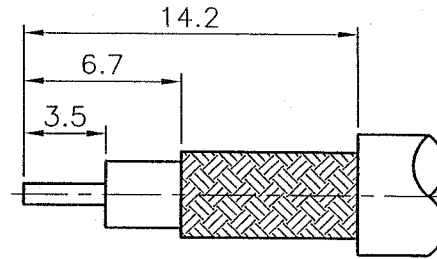
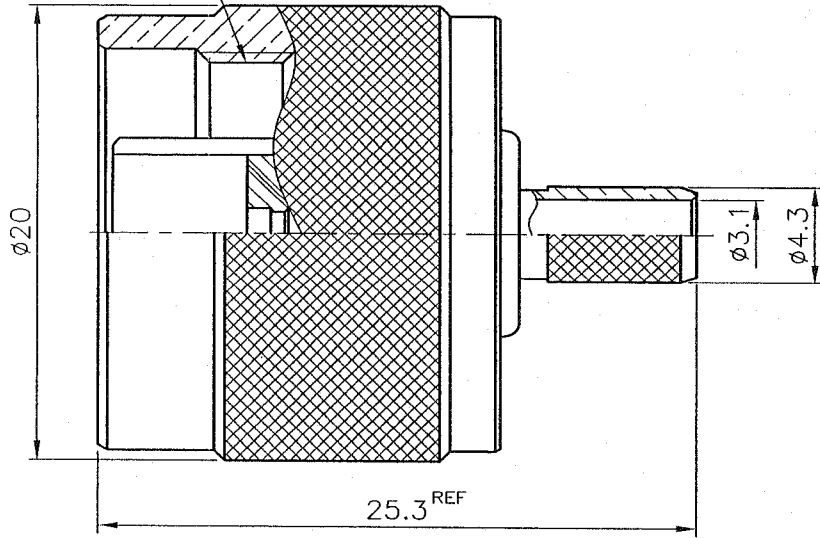

RECOMMENDED
CABLE STRIPPING DIM'S
(建議剝線尺寸)

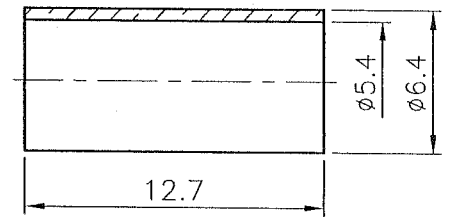
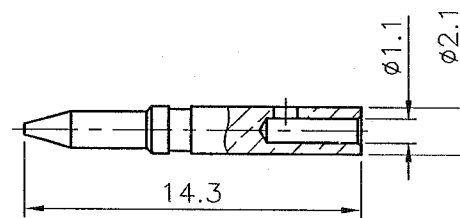

NOTES: FINISH (PLATING THICKNESS IN MICRO-INCHES)

1. BRASS PER QQ-B-626
2. NICKEL PL 70 MIN THICK OVER COPPER STRIKE
3. TEFLON MIL-P-19468
4. GOLD PL 3 MIN THICK OVER NICKEL PL 70 MIN THICK OVER COPPER STRIKE
5. BRASS JIS H 3250,C 2700

1. CRIMPED FERRULE
HEX CRIMP SIZE .213" (5.41mm)
(套管壓著工具)
2. CRIMPED CONTACT PIN
HEX CRIMP SIZE .068" (1.72mm)
(中心針壓著工具)



NO.	DESCRIPTION	MATERIAL	FINISH	Q'TY	DRAWING NO.	SCALE	3/1	ISSUE	A1
	FERRULE		NOTE 5	NOTE 2					
	CONTACT PIN		NOTE 1	NOTE 4					
	SHELL		NOTE 1	NOTE 2					
	C RING		NOTE 1	NOTE 2					
	GASKET	SILICONE		RED					
	INSULATOR		NOTE 3	WHITE					
	BRAID HOLDER		NOTE 1	NOTE 2					
	BODY		NOTE 1	NOTE 2					

DIMENSIONS ARE IN MILLIMETERS
UNLESS OTHERWISE SPECIFIED
TOLERANCES
(一般公差)
0.5~6 = ±0.2
>6~30 = ±0.4
>30~120 = ±0.6
>120~315 = ±1
>315~1000 = ±1.6
ANGLES(角度) = ±5'

PART NO.	
APPROVED	DATE
<i>[Signature]</i>	08/22/06'
CHECKED	DATE
<i>[Signature]</i>	08/22/06'
DRAWN	DATE
<i>[Signature]</i>	08/22/06'

BO-JIANG 帛江科技股份有限公司
BO-JIANG TECHNOLOGY CO., LTD.

TITLE: N CRIMP PLUG
(FOR RG-58C/U,58/U)

DRAWING NO. 7311NS501BF000B

FILE NO. Z:\NND\7311\NS\501\000\BFB-A1