

REVISIONS

ISS SYMBOL	DESCRIPTION\DATE
A1	由BJ-9658-09BGTG 型號轉來, 並符合RoHS\ 02/26/07'

FOR CUSTOMER

REMARK: RoHS COMPLIANT
(符合 RoHS)

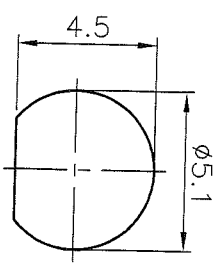
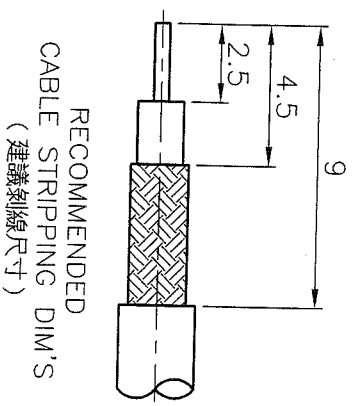
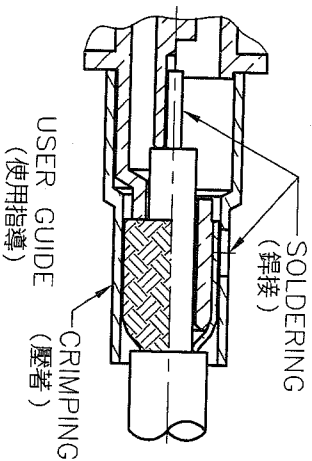

RECOMMENDED MOUNTING HOLE
(建議架設孔)

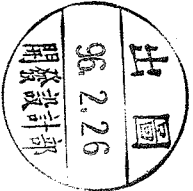
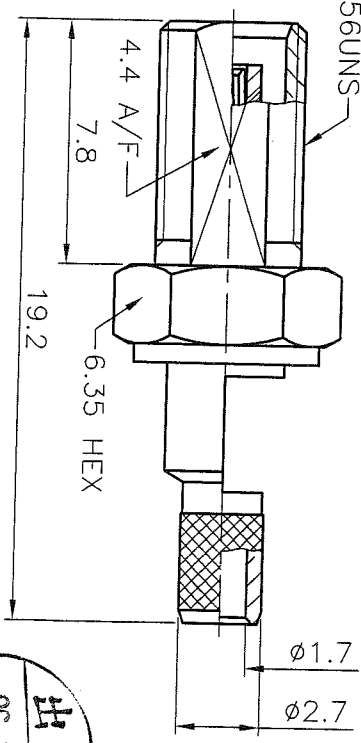
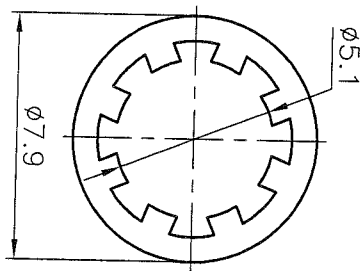
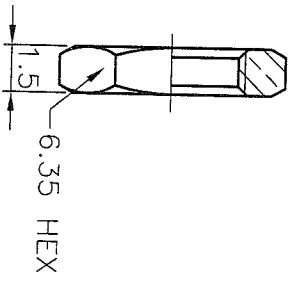

- NOTES: FINISH (PLATING THICKNESS IN MICRO-INCHES)
1. BRASS PER QQ-B-626
 2. GOLD PL 3 MIN OVER NICKEL PL 70 MIN THICK OVER COPPER STRIKE
 3. GOLD PL 30 MIN OVER NICKEL PL 70 MIN THICK OVER COPPER STRIKE
 4. TEFLON MIL-P-19468
 5. BERYLLIUM COPPER PER QQ-C-530
 6. BRASS PER QQ-B-613

1. CRIMPED FERRULE HEX CRIMP SIZE .128" (3.25mm) (套管壓著工具)
2. CONTACT PIN TO SOLDER (中心針焊接)
3. MAX. PANEL THICKNESS=5.3mm (最大板厚)

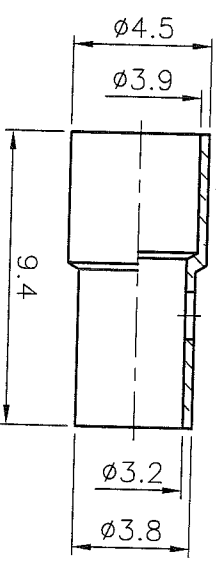

NO.	DESCRIPTION	MATERIAL	FINISH	Q'TY	DRAWING NO.	SCALE	4/1	ISSUE	A1
	NUT		NOTE 1	NOTE 2					
	WASHER		NOTE 6	NOTE 2					
	FERRULE		NOTE 1	NOTE 2					
	BRAID HOLDER		NOTE 1	NOTE 2					
	CONTACT PIN		NOTE 5	NOTE 3					
	INSULATOR		NOTE 4	WHITE					
	BODY		NOTE 1	NOTE 2					

DIMENSIONS ARE IN MILLIMETERS
UNLESS OTHERWISE SPECIFIED
TOLERANCES
(一般公差)

- 0.5~6 = ±0.2
- >6~30 = ±0.4
- >30~120 = ±0.6
- >120~315 = ±1
- >315~1000 = ±1.6
- ANGLES(角度) = ±5'

PART NO.	
APPROVED	DATE
CHECKED	DATE
DRAWN	DATE

3 帛江科技股份有限公司
BO-JIANG TECHNOLOGY CO., LTD.
MCX BULKHEAD CRIMP JACK
(FOR RG-174/U, 188A/U, 316/U)

DRAWING NO. **9661BS509BD001B**

FILE NO. Z:\NND\9661\BS\509\001\9661BS509BD001B-A1