

REVISIONS		
ISS	SYMBOL	DESCRIPTION\DATE
A1		由BJ-7033-81BNTG001-R 型號轉來\01/03/07'

REMARK: RoHS COMPLIANT  
(符合 RoHS)

FOR CUSTOMER

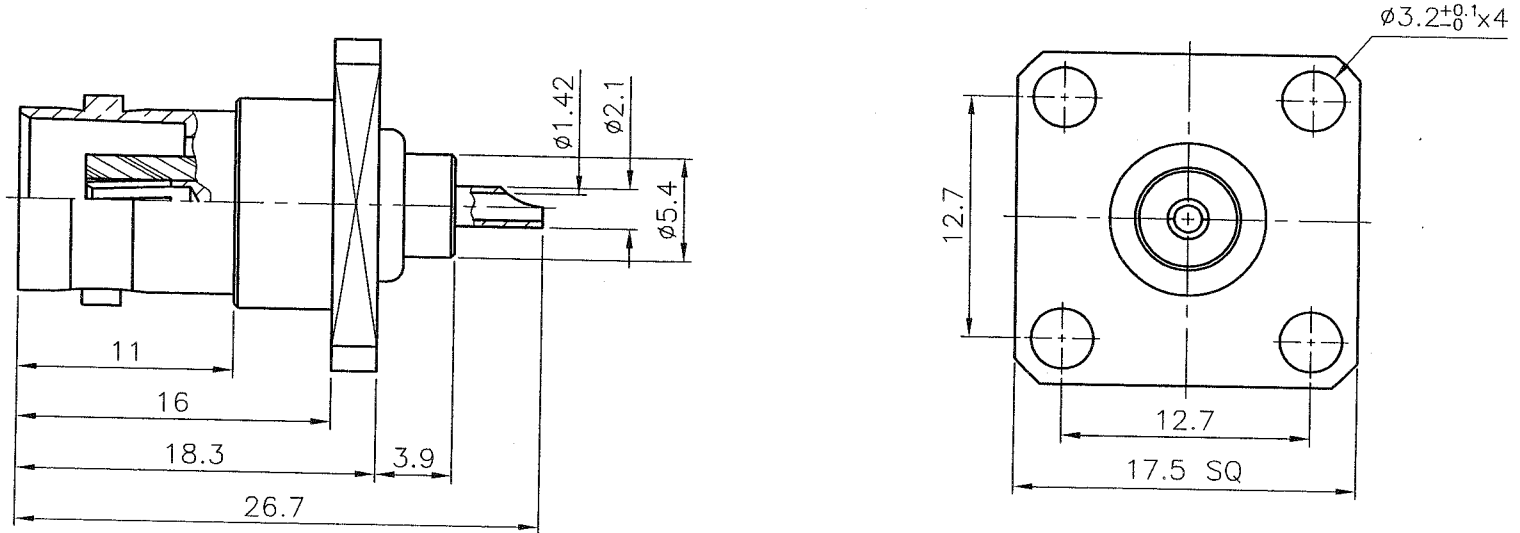

NOTES: FINISH (PLATING THICKNESS IN MICRO-INCHES)

1. BRASS PER QQ-B-626
2. NICKEL PL 70 MIN THICK OVER COPPER STRIKE
3. GOLD PL 3 MIN OVER NICKEL PL 70 MIN THICK OVER COPPER STRIKE
4. TEFLON MIL-P-19468
5. PHOSPHOR BRONZE PER QQ-B-750



					DIMENSIONS ARE IN MILLIMETERS			PART NO.		
					UNLESS OTHERWISE SPECIFIED TOLERANCES (一般公差) 0.5~6 = $\pm 0.2$ >6~30 = $\pm 0.4$ >30~120 = $\pm 0.6$ >120~315 = $\pm 1$ >315~1000 = $\pm 1.6$ ANGLES(角度) = $\pm 5'$			APPROVED		DATE
								CHECKED		DATE
								DRAWN		DATE
										DATE
CONTACT PIN	NOTE 5	NOTE 3						BO-JIANG BO-JIANG TECHNOLOGY CO., LTD.		
INSULATOR	NOTE 4	WHITE						TITLE BNC PANEL RECEIPT JACK		
BODY	NOTE 1	NOTE 2						DRAWING NO. 7069FS501BF002B		
NO.	DESCRIPTION	MATERIAL	FINISH	Q'TY	DRAWING NO.	SCALE	2.5/1	ISSUE	A1	FILE NO. Z:\NND\7069\F5\501\002\7069FS501BF002B-A1