

REVISIONS	
ISS	SYMBOL
DESCRIPTION \ DATE	

FOR CUSTOMER

REMARK: RoHS COMPLIANT  
(符合 RoHS)

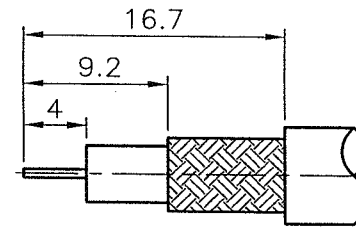

RECOMMENDED  
CABLE STRIPPING DIM'S  
(建議剝線尺寸)

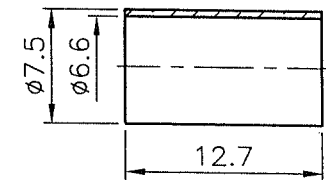
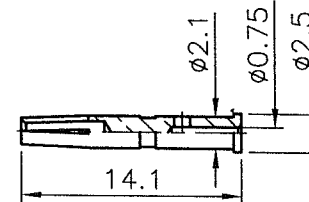
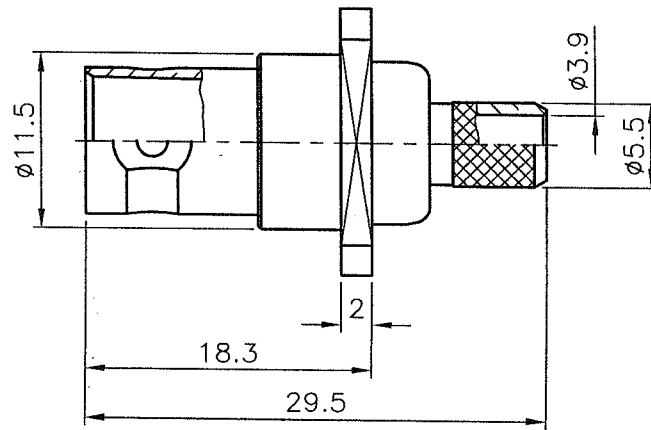
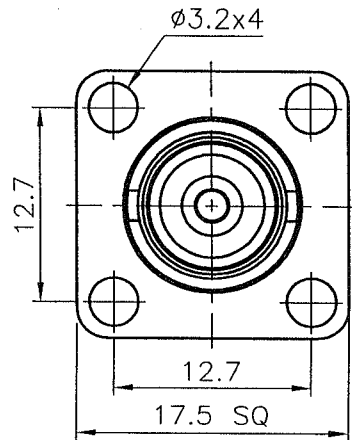

NOTES: FINISH (PLATING THICKNESS IN MICRO-INCHES)

1. BRASS PER QQ-B-626
2. NICKEL PL 70 MIN THICK OVER COPPER STRIKE
3. GOLD PL 3 MIN OVER NICKEL PL 70 MIN THICK OVER COPPER STRIKE
4. PHOSPHOR BRONZE PER QQ-B-750
5. BRASS JIS H 3250, C 2700

1. CRIMPED FERRULE  
HEX CRIMP SIZE .255" (6.48mm)  
(套管壓著工具)
2. CRIMPED CONTACT PIN  
HEX CRIMP SIZE .068" (1.72mm)  
(中心針壓著工具)

				DIMENSIONS ARE IN MILLIMETERS				PART NO.		<b>帛江科技股份有限公司</b> <b>BO-JIANG TECHNOLOGY CO., LTD.</b>	
				UNLESS OTHERWISE SPECIFIED TOLERANCES (一般公差)				APPROVED	DATE		TITLE
				0.5~6 = ±0.2				<i>[Signature]</i>	10/04/06'		
				>6~30 = ±0.4				CHECKED	DATE		DRAWING NO.
				>30~120 = ±0.6				<i>[Signature]</i>	10/04/06'		
				>120~315 = ±1				DRAWN	DATE	FILE NO. Z:\NND\7061\FS\705\000\CFB-A1	
				>315~1000 = ±1.6				<i>[Signature]</i>	10/04/06'		
				ANGLES(角度) = ±5'							
FERRULE	NOTE 5	NOTE 2									
CONTACT PIN	NOTE 4	NOTE 3									
PANEL	NOTE 1	NOTE 2									
BRAID HOLDER	NOTE 1	NOTE 2									
INSULATOR	DELFIN	WHITE									
BODY	NOTE 1	NOTE 2									
NO.	DESCRIPTION	MATERIAL	FINISH	Q'TY	DRAWING NO.	SCALE	2/1	ISSUE	A1		