

REVISIONS	
ISS	SYMBOL
DESCRIPTION \ DATE	
A1	由R7024-BNDGA09 型號轉來 \ 11/20/08'

FOR CUSTOMER

REMARK: RoHS COMPLIANT
(符合 RoHS)

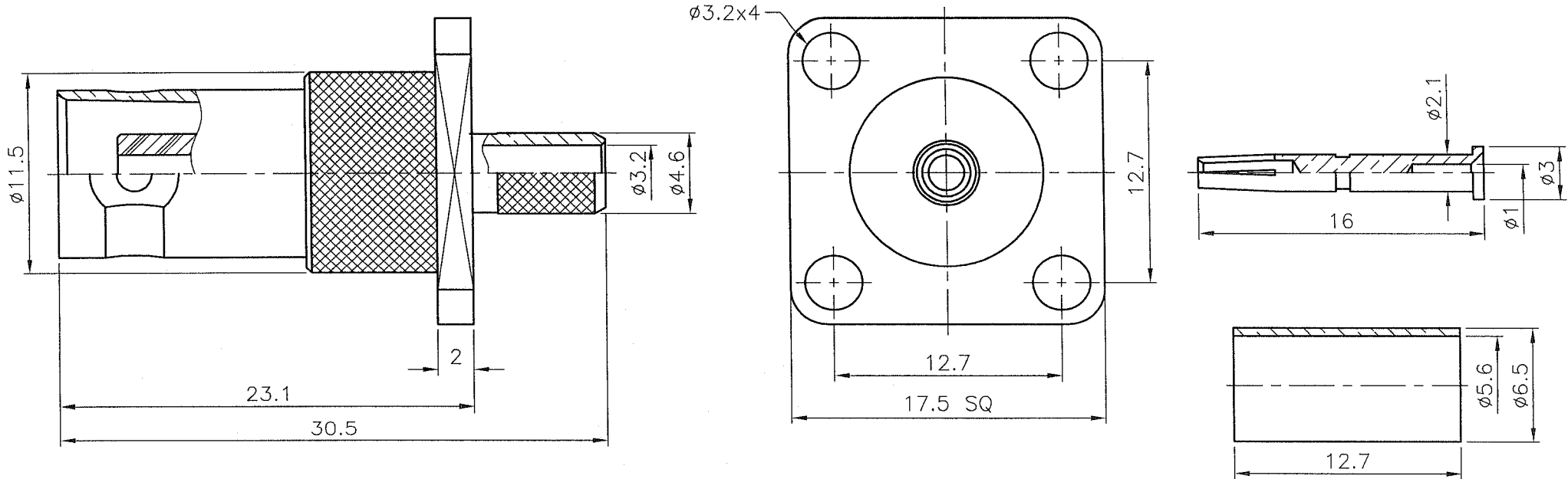

NOTES: FINISH (PLATING THICKNESS IN MICRO-INCHES)

1. BRASS PER QQ-B-626
2. NICKEL PL 70 MIN THICK OVER COPPER STRIKE
3. GOLD FLUSH OVER NICKEL PL 70 MIN THICK OVER COPPER STRIKE
4. BRASS JIS H 3250, C 2700



1. CRIMPED FERRULE
HEX CRIMP SIZE .213" (5.41mm)
(套管壓著工具)
2. CRIMPED CONTACT PIN
HEX CRIMP SIZE .068" (1.72mm)
(中心針壓著工具)

					DIMENSIONS ARE IN MILLIMETERS				PART NO.		BO-JIANG BO-JIANG TECHNOLOGY CO., LTD.	
FERRULE	NOTE 4	NOTE 2			UNLESS OTHERWISE SPECIFIED TOLERANCES (一般公差) 0.5~6 = ± 0.2 >6~30 = ± 0.4 >30~120 = ± 0.6 >120~315 = ± 1 >315~1000 = ± 1.6 ANGLES(角度) = $\pm 5^\circ$	APPROVED	DATE	TITLE BNC PANEL CRIMP JACK (FOR RG-58/U)				
CONTACT PIN	NOTE 1	NOTE 3				<i>[Signature]</i>	11/20/08'					
PANEL	NOTE 1	NOTE 2				CHECKED	DATE	DRAWING NO. 7061FS501CF001B				
LOCK RING	NOTE 1	NOTE 2				<i>[Signature]</i>	11/20/08'					
INSULATOR	DEL RIN	WHITE				DRAWN	DATE	FILE NO. Z:\NND\7061\FS\501\001\7061FS501CF001B-A1				
BODY	NOTE 1	NOTE 2			<i>[Signature]</i>	11/20/08'						
NO.	DESCRIPTION	MATERIAL	FINISH	Q'TY	DRAWING NO.	SCALE	3/1	ISSUE	A1			