

REVISIONS

ISS	SYMBOL	DESCRIPTION\DATE
A1		由BJ-7001-01BNTG-R 型號轉來\05/23/07'
A2		GASKET 材質更改為 SILICONE \09/12/08'

REMARK: RoHS COMPLIANT
(符合 RoHS)

FOR CUSTOMER

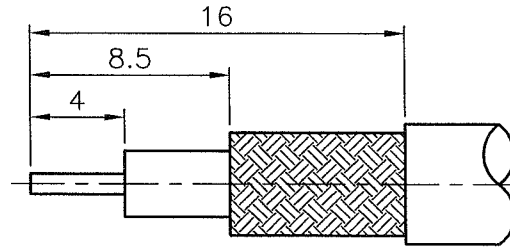

RECOMMENDED
CABLE STRIPPING DIM'S
(建議剝線尺寸)

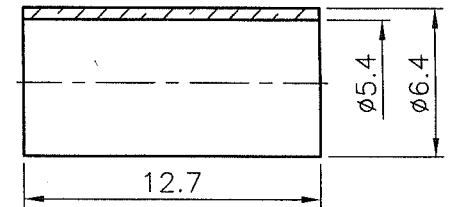
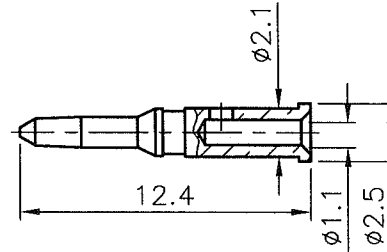
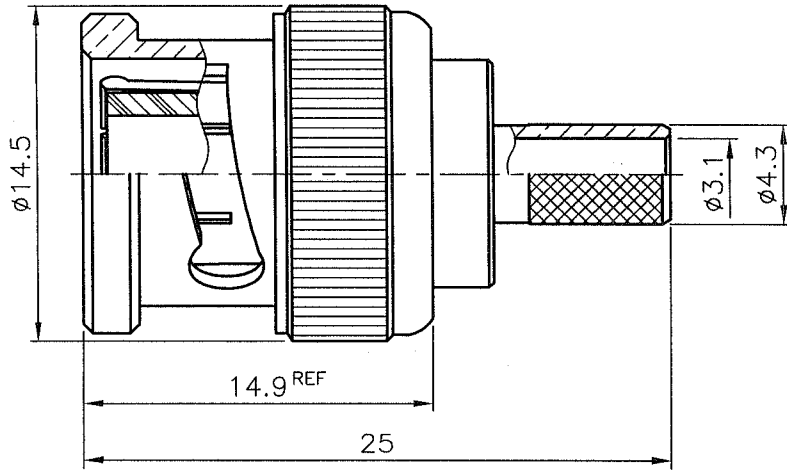

NOTES: FINISH (PLATING THICKNESS IN MICRO-INCHES)

1. BRASS PER QQ-B-626
2. NICKEL PL 70 MIN THICK OVER COPPER STRIKE
3. GOLD PL 3 MIN OVER NICKEL PL 70 MIN THICK OVER COPPER STRIKE
4. TEFLON MIL-P-19468
5. BRASS JIS H 3250, C 2700

1. CRIMPED FERRULE
HEX CRIMP SIZE .213" (5.41mm)
(套管壓著工具)
2. CRIMPED CONTACT PIN
HEX CRIMP SIZE .068" (1.72mm)
(中心針壓著工具)

NO.	DESCRIPTION	MATERIAL	FINISH	Q'TY	DRAWING NO.
	FERRULE	NOTE 5	NOTE 2		
	CONTACT PIN	NOTE 1	NOTE 3		
	SHELL	NOTE 1	NOTE 2		
	GASKET	SILICONE	RED		
	C RING	SS41	NOTE 2		
	SPRING	SK5	NOTE 2		
	WASHER	SS41	NOTE 2		
	INSULATOR	NOTE 4	WHITE		
	BODY	NOTE 1	NOTE 2		

DIMENSIONS ARE IN MILLIMETERS

UNLESS OTHERWISE SPECIFIED
TOLERANCES
(一般公差)
0.5~6 = ±0.2
>6~30 = ±0.4
>30~120 = ±0.6
>120~315 = ±1
>315~1000 = ±1.6
ANGLES(角度) = ±5'

PART NO.

APPROVED DATE

CHECKED DATE

DRAWN DATE

BO-JIANG 帛江科技股份有限公司
BO-JIANG TECHNOLOGY CO., LTD.

TITLE
BNC CRIMP PLUG
(FOR RG-58C/U, 58/U)

DRAWING NO. **7011NS501BF000B**

FILE NO. Z:\NND\7011\NS\501\000\7011NS501BF000B-A2

AWL 09/12/08'